



Hygienic Swing Doors

Double Action - Seamless Moulded Fiberglass
Non Fire Rated, Manual



LEADING EDGE TECHNOLOGY FOR SUPERIOR HYGIENE PERFORMANCE

Dortek's hygienic door systems are manufactured using cutting edge technology and a revolutionary closed mould process. This creates a strong, uniform product with no seams or joins on the door surface and no voids, holes or crevices within for bacteria to harbor.

We are market specialists; with over 45 years experience in providing high performance door solutions to the worlds leading pharmaceutical, food and healthcare companies.

We understand the unique and stringent requirements of high hygiene environments. We understand air flows, contaminants and local regulations. We know what works and what doesn't. Our product portfolio offer a comp clients comprehensive single source for all doors, hardware and automations on a project.

As a leading single source supplier, we can satisfy diverse customer needs, offering you the benefits of our extensive manufacturing capability, technical expertise and innovative product solutions.

SUPERIOR HYGIENE

Flush seamless surface for a smooth attractive finish which is easy to keep clean. Free from organic materials, ledges and gaps to eliminate breeding grounds for bacteria

INTELLIGENT DESIGN

Proven to maximise efficiency, safety and hygiene in the most demanding environments. These doors will not rot, rust, swell, warp or corrode. Designed to meet FDA and cGMP requirements

CHEMICAL RESISTANT

Smooth, sealed, non absorbent surface which is easy to clean. Excellent resistance to most disinfectants, solvents and strong chemicals,

ULTIMATE DURABILITY

Extremely strong, reliable and designed for high usage environments. These doors out-perform wood and steel alternatives, bringing you a lifetime of durability and the ultimate cost-effective solution

MAXIMUM EFFICIENCY

Proven to prevent air leakage and save energy costs. These doors make optimal use of room space and cause less accidents when opening and closing

UNRIVALLED QUALITY

Engineered to offer supreme quality and reliability.

COMPLETE TURNKEY SYSTEM

Dortek provides complete access solutions which are individually crafted to meet your specification. We offer a choice of colored door panels, frames, hardware, vision panels, access controls.



DORTEK
Opening Innovation

TECHNICAL FEATURES

DOORLEAF

Seamless fiberglass encapsulating a non-organic, high density polyisocyanurate foam core

Total thickness 1.57" (40mm) or 1.75" (44mm)

Internal aluminum reinforcement for hardware fixing

Moisture absorption zero

SIZES

Molded in 11 standard widths and four heights

Also available for special order in any non-standard height

FRAMES

Available in 4 frame types: FRP, SS, Aluminium or Powder Coated Steel

- Seamless glass fiber reinforced polyester with insert for screw fixing direct to structure
- Satin anodised or powder coated white adjustable width aluminium frame, incorporating a neoprene seal for screw fixing to a sub frame
- Alternative stainless steel frames for fixing to installation panel and block work. Doors can be supplied for fixing to clients'

FINISH

- Easy to clean, maintenance free, smooth, non porous, gelcoat surface with built-in choice of 20 colors

OPTIONS

Factory-fitted hardware and door protection

20ga stainless steel edge protection

Flush vision panels with integral blinds, smart glass or x-ray and laser protection

Automations & Interlocking.

ARCHITECTURAL DETAILS

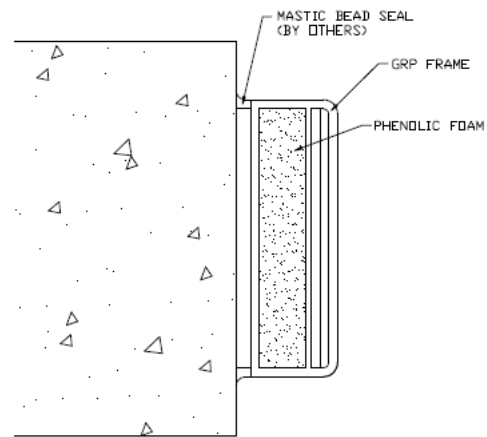
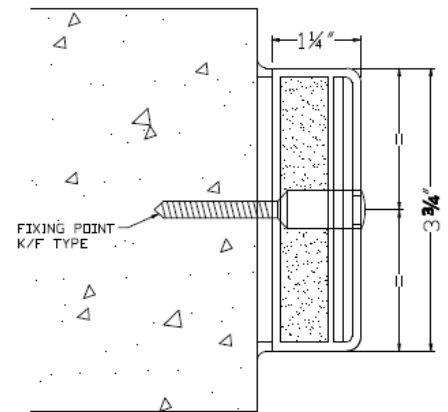

USA

Dortek Inc
10 East 6TH Avenue, Suite 310
Conshohocken
Pennsylvania
PA 19428

Tel Office: +1 610 234 7276

Sales: +1 617 401 8226

Email: us-sales@dortek.com

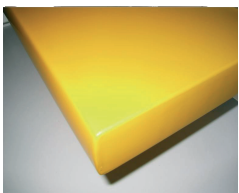

Seamless Fiberglass Door Panel



Optional flush vision panel



Factory fitted hardware

