

1

BROOMSTOW

MOP / BROOM / UTENSIL
HOLDER

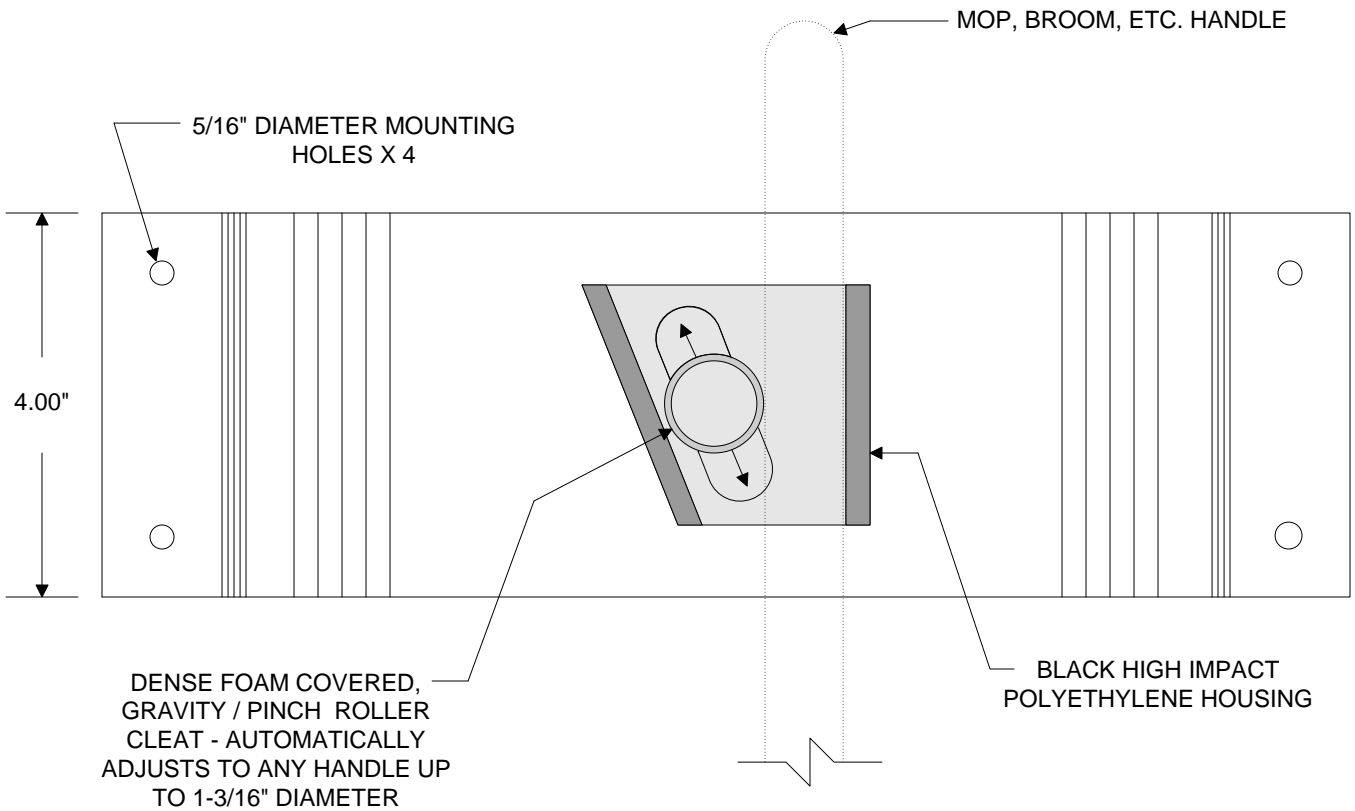
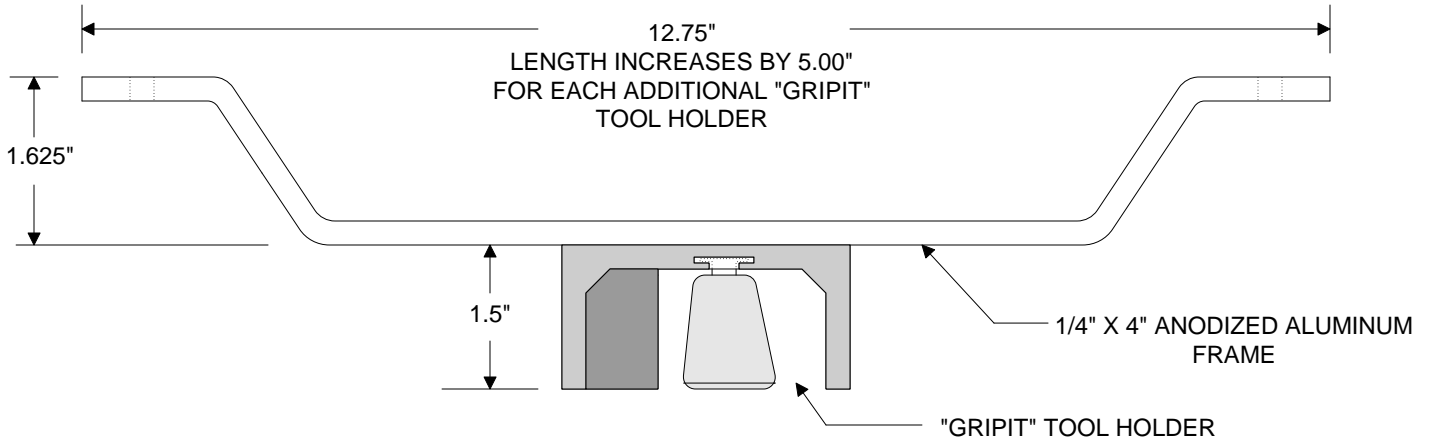

BSG-1 SHOWN:
AVAILABLE WITH ANY NUMBER OF
"GRIPIT " TOOL HOLDERS REQUIRED-
BSG-3 IS TYPICAL

ISSUE		DATE	LIFE SCIENCE PRODUCTS, INC 124 Speer Rd. Chestertown, Md 21620 410-778-6474	
			JOB:	
			ADDRESS:	
			JOB #:	
			CONTR:	
			DRAWN BY:	SHEET#